

# In-Line Cluster Mounting Bracket

## Designed for CPS 250/275 kW Inverters & 800 Vac AC Combiners

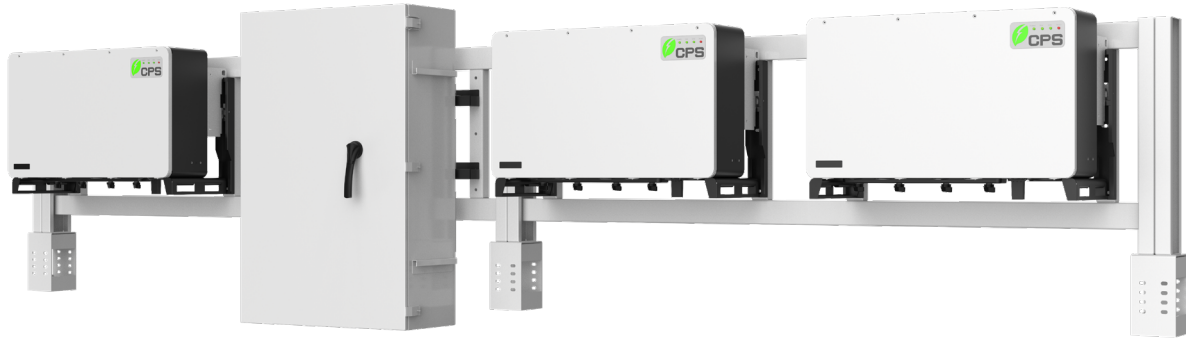

**CPS In-Line Cluster Mounting Bracket**

The CPS In-Line Cluster Mounting Bracket is designed to provide a simple, low-cost mounting solution for CPS 250/275 kW inverters and CPS 800 Vac 3:1 AC Combiners. (3) CPS 250/275 kW and (1) 800 Vac AC Combiner can be mounted onto piles to easily install the equipment for ground mount PV applications. This solution enables savings on labor and material costs for system designs and installation.

### Key Features

- Easily mount (3) 250/275 kW inverters and (1) 800 Vac AC Combiner
- Simplifies Inverter and Combiner installation
- Cost-efficient mounting solution
- Includes mounting bracket for CPS 800 Vac AC Combiner
- In-line design to allow efficient working space

Model Name	CPS In-Line Cluster Mounting Bracket
<b>Mechanical</b>	
Material	DC51D-ZM180 steel
Dimensions (H x W x D)	46.3 x 231.4 x 6.8 in (1,175 x 5,877 x 172 mm)
Dimensions of total Cluster Mounting Bracket including (3) 250/275 kW Inverters + (1) 800 Vac AC Combiner	55.1 x 231.4 x 23.3 in (1,400 x 5,877 x 643 mm)
Total weight of Cluster Rack	264 lbs / 120 kg
Compatible inverters	CPS SCH275KTL-DO/US-800
Compatible combiner	CPS DPA03-800V/US
Installation method	Mounted to 3 piles (piles not included)
<b>Warranty</b>	
Standard	2 years

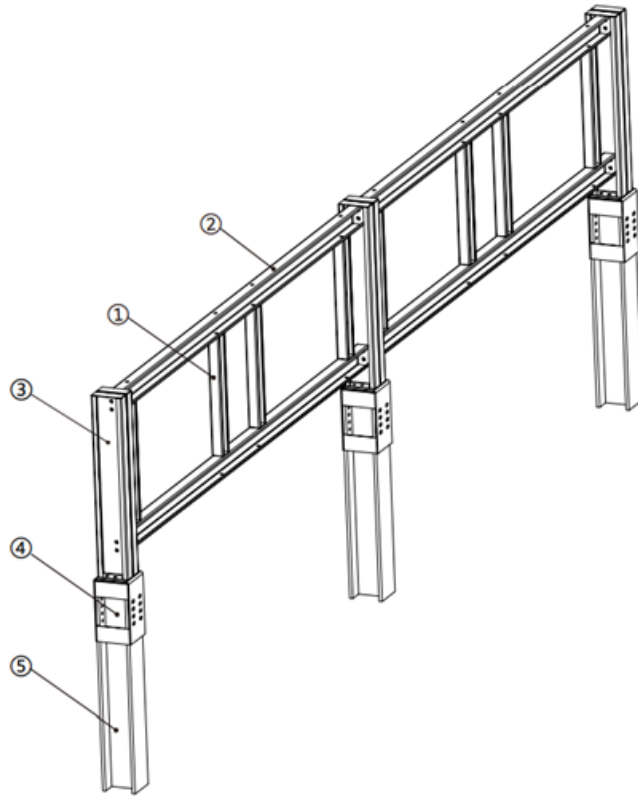

### Cluster Components

Item No.	Component Name	Quantity
1	Equipment installation vertical beam	8
2	Beam	4
3	Vertical beam	6
4	Pile connector	3
5	Pile	3 (user supplied)